



Multi-Unit PureCell[®] Model 400 Microgrids

[A HyAxiom White Paper](#)

Introduction

In addition to providing efficient, clean and reliable baseload electric and thermal energy, PureCell® Model 400 Power Plants can be configured to also provide these benefits in a microgrid in the event of a loss of the utility grid. The PureCell® Microgrid Power Block provides seamless transfer from grid connected to islanded microgrid operation and leverages the unique PureCell® Model 400 load dispatch capability to continuously supply highly variable microgrid loads. The solution is scalable from 800kW to 5MW.

PureCell® Microgrid Power Block Description

Figures 1&2 depict HyAxiom's 2-unit fuel cell microgrid power block consisting of:

- (2) PureCell® Model 400 Power Plants
- (1) Energy Storage System (ESS) consisting of:
 - Lithium Ferro-Phosphate Battery
 - Power Conditioning System (bi-directional inverter)
- (1) Energy Management System (EMS)
- (1) Static Transfer Switch (STS)

The system is scalable by adding PureCell® Model 400 Power Plants and increasing the size of the ESS.

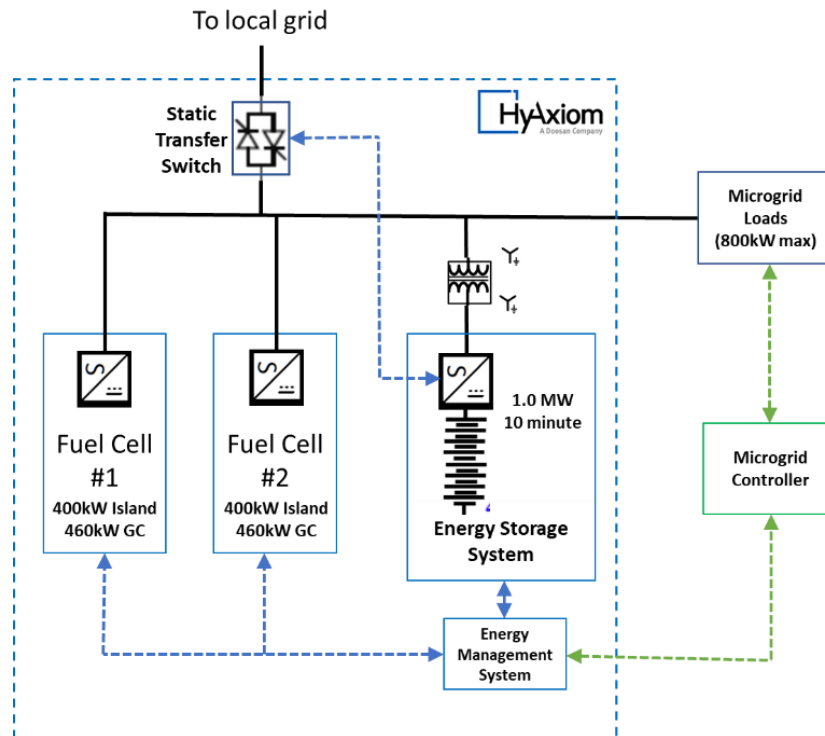

Figure 1. 800 kW Fuel Cell Microgrid Power Block

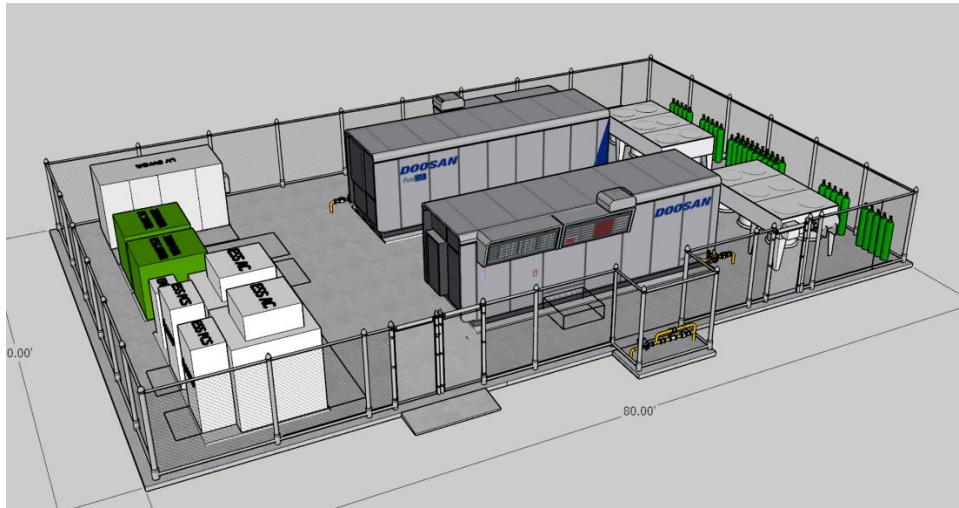

Figure 2. Fuel Cell Microgrid Power Block – Typical Layout

Normal Grid-Connected Operation (Figure 3)

During normal operation, the microgrid is connected to the local electric system via the STS. Fuel Cells #1 & #2 are operating base loaded up to a rated load of 460 kW per power plant and serving facility electrical and thermal loads. The ESS is maintaining a standby state-of-charge and monitoring for a change in grid status.

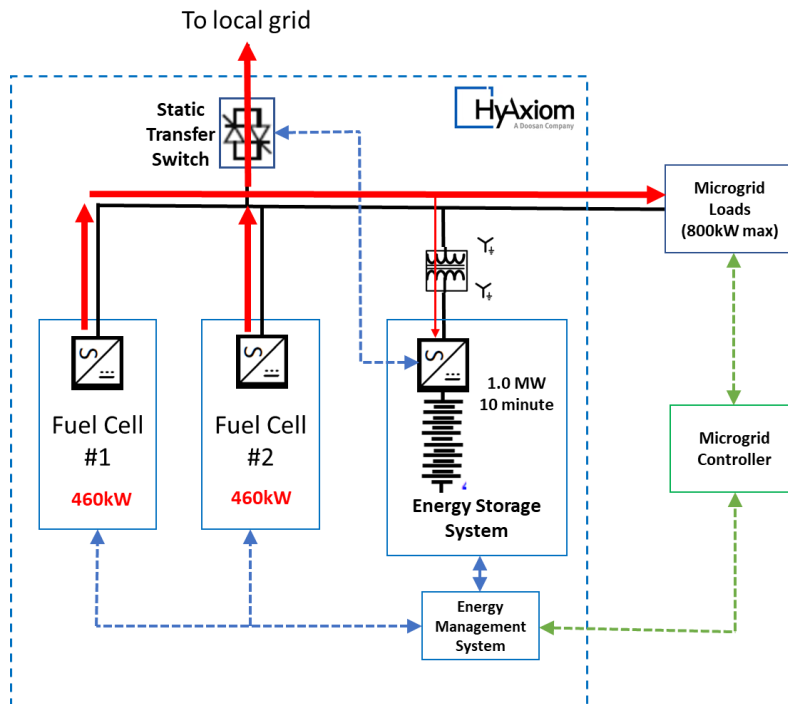

Figure 3. Fuel Cell Microgrid Power Block – Grid Connected Operation

Grid Faulted Microgrid Operation (Figure 4):

In the event of a grid disturbance or outage, the STS will disconnect the microgrid from the local utility grid in approximately ¼ of a cycle (4 ms). The ESS instantly and seamlessly begins supplying the microgrid load while regulating system voltage and frequency.

Simultaneously, the EMS commands Fuel Cells #1 & #2 to Idle mode; disconnected from the microgrid and supplying their internal, parasitic loads. The EMS then sends power setpoints to Fuel Cells #1 & #2 to supply the microgrid loads. The fuel cells will ramp at 10 kW/sec to the power setpoints, allowing the ESS to stop discharging and maintain its desired state-of-charge.

As microgrid load varies up or down, the ESS will immediately produce or absorb power to maintain voltage and frequency. The EMS will calculate new power setpoints to Fuel Cells #1 & #2 as necessary to maintain the desired ESS state-of-charge.

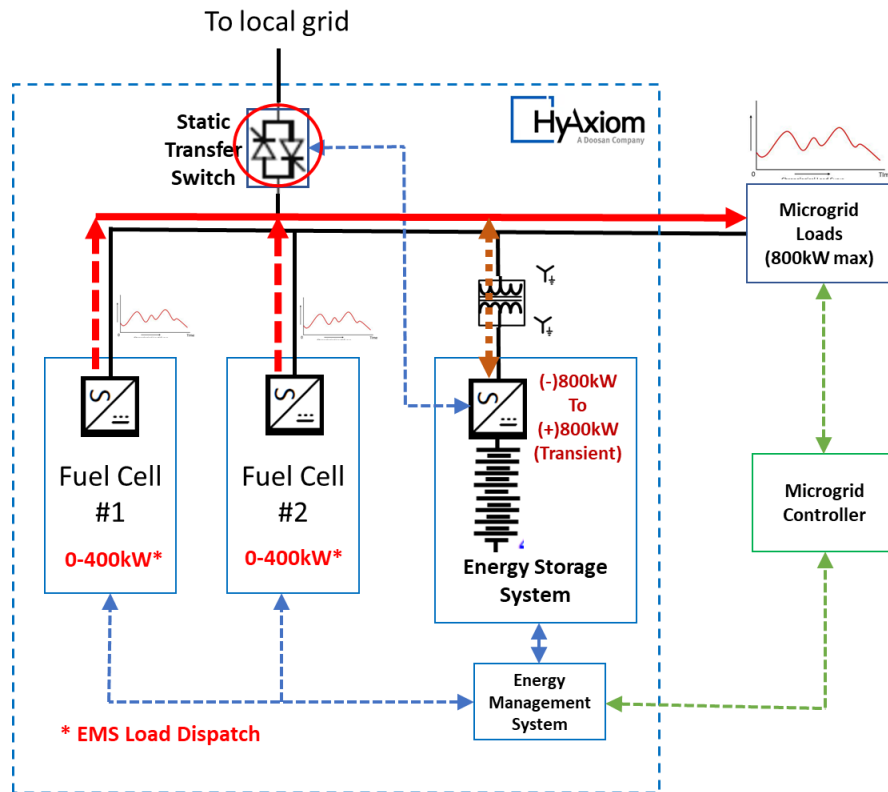

Figure 4. Fuel Cell Microgrid Power Block – Microgrid Operation

Depending on the size and complexity of the site electrical system, a microgrid controller may be needed to isolate, segregate, and prioritize loads and coordinate utility interconnection.

A microgrid controller can provide enhanced microgrid resiliency in the event one of the fuel cell power plants were to go off-line. In this case, the ESS seamlessly and instantly picks up the load that was being carried by the faulted fuel cell power plant. The EMS would signal to the site microgrid controller that the maximum power available has reduced from 800kW to 400kW. The microgrid controller could then shed lower priority loads and the system would continue operating at reduced load capability.

N+1 High Reliability Configuration

In mission critical applications requiring high reliability, full capacity microgrid power, the PureCell® Microgrid Power Block can be configured with N+1 redundancy as described below.

Figure 5 depicts a 5-unit Fuel Cell Microgrid Power Block. Instead of a maximum microgrid design load of 2000kW, the microgrid maximum design load is limited to 1600kW to achieve N+1 redundancy. For this example, a worse case microgrid load of 1600kW is assumed. The five PureCell® Model 400 Power Plants are each carrying 320kW of microgrid load. The ESS is regulating voltage and frequency and maintaining its desired state of charge.

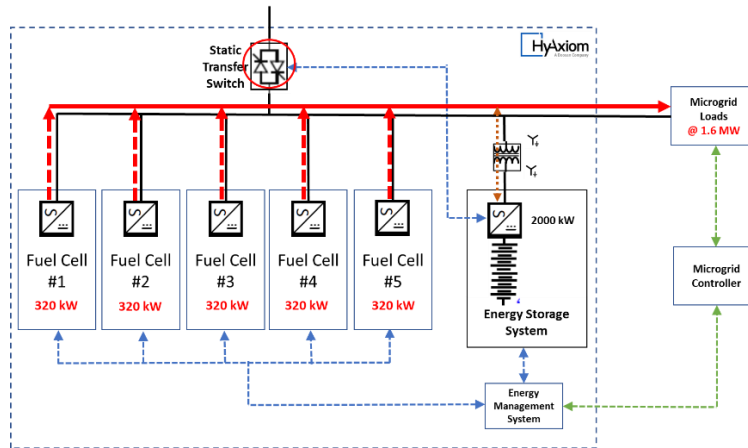

Figure 5. N+1 Fuel Cell Microgrid Power Block – Normal Microgrid Operation

As shown in Figure 6 below, a postulated fault takes Fuel Cell #5 off-line. Instantly and seamlessly, the ESS picks up the 320kW of microgrid load shed by Fuel Cell #5. The EMS increases the load dispatch setpoints to Fuel Cells #1-4 from 320kW to 400kW. Fuel Cells #1-4 ramp to their new power setpoints in 8 seconds, allowing the ESS to stop discharging power and maintain its steady-state charge level.

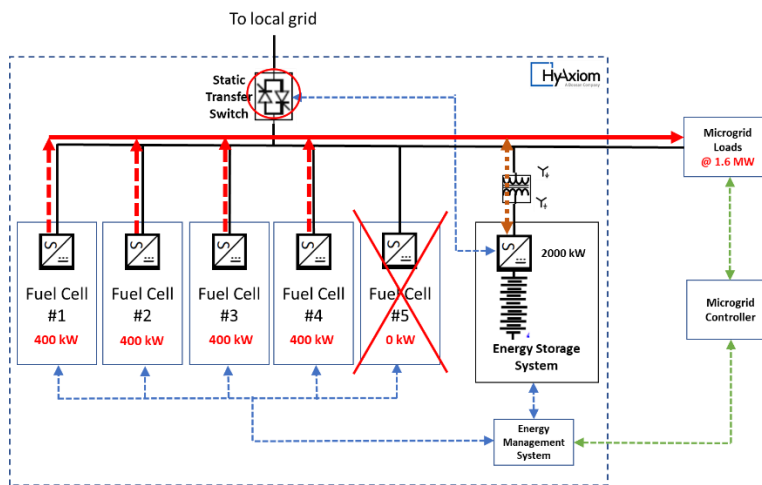

Figure 6. N+1 Fuel Cell Microgrid Power Block –Microgrid Operation w/fault

Conclusion

The flexible, scalable PureCell® Microgrid Power Block provides premium power in off-grid and microgrid applications requiring continuous, reliable power for critical loads. This is achieved while also providing seamless transitions to and from grid connected operations and excellent load following capability.