

**DEPARTMENT OF CITY PLANNING**  
**GENERALIZED SUMMARY OF ZONING REGULATIONS**  
*Updated March 2020*



**Table 1 – General Development Standards**

| Zone                                     | Use  | Maximum Height |                   | Required Yards  |   |                          | Minimum Area  |   | Min. Lot Width  | Parking Required  |
|--|--|----------------|-------------------|---|---|--------------------------|---|---|---|---|
|  |  | Stories        | Feet              | Front   | Side  | Rear                     | Per Lot   | Per Dwelling Unit   |   |   |
| <b>Agricultural</b>                      |  |                |                   |   |   |                          |   |   |   |   |
| <b>A1</b>                                | <b>Agriculture</b><br>One-Family Dwellings, Parks, Playgrounds, Community Centers, Golf Courses, Agricultural Uses                                     | Unlimited (9)  | 45 or (6a), (9)   | 20% lot depth; 25 ft max or (6a)                            | 10% of lot width; 25 ft max or (6a)                         | 25% lot depth; 25 ft max | 5 acres   | 2.5 acres   | 300 ft  | 2 spaces per dwelling unit (6a)   |
| <b>A2</b>                                | <b>Agriculture</b><br>A1 uses  |                |                   |   |   |                          | 2 acres   | 1 acre  | 150 ft  | Bicycle Parking pursuant to Sec. 12.21 A.16 of the LAMC   |
| <b>RA</b>                                | <b>Suburban</b><br>Limited Agricultural Uses, One-Family Dwellings, Home Occupations   |                |                   |   |   |                          | See Table 2 below   | 20% lot depth; 25 ft max, but not less than prevailing (6b) | 10 ft min; for lots recorded prior to 7/1/66, 10% lot width where lot is < 70 ft wide, not less than 3 ft (7); for Hillside Area lots see Sec. 12.21 C.10 of the LAMC | 17,500 sq-ft (1)  |
| <b>Residential Estate</b>                |  |                |                   |   |   |                          |   |   |   |   |
| <b>RE40</b>                              | <b>Residential Estate</b><br>One-Family Dwellings, Parks, Playgrounds, Community Centers, Truck Gardening, Accessory Living Quarters, Home Occupations | Unlimited (9)  | See Table 2 below | 20% lot depth; 25 ft max, but not less than prevailing (6b) | 10 ft (7)   | 25% lot depth; 25 ft max | 40,000 sq-ft (1)  | 40,000 sq-ft (1)  | 80 ft (1)   | 2 covered spaces per dwelling unit (8)<br><br>Bicycle Parking pursuant to Sec. 12.21 A.16 of the LAMC |
| <b>RE20</b>                              |  |                |                   |   |   |                          | 20,000 sq-ft (1)  | 20,000 sq-ft (1)  |   |   |
| <b>RE15</b>                              |  |                |                   |   |   |                          | 15,000 sq-ft (1)  | 15,000 sq-ft (1)  |   |   |
| <b>RE11</b>                              |  |                |                   |   |   |                          | 11,000 sq-ft (1)  | 11,000 sq-ft (1)  | 70 ft (1)   |   |
| <b>RE9</b>                               |  |                |                   |   |   |                          | 9,000 sq-ft (1)   | 9,000 sq-ft (1)   | 65 ft (1)   |   |
| <b>One-Family Residential</b>            |  |                |                   |   |   |                          |   |   |   |   |
| <b>RS</b>                                | <b>Suburban</b><br>One-Family Dwellings, Parks, Playgrounds, Community Centers, Truck Gardening, Home Occupations                                      | Unlimited (9)  | See Table 2 below | 20% lot depth; 25 ft max, but not less than prevailing (6b) | 5 ft; or 10% lot width < 50 ft wide, not less than 3 ft (7) | 20 ft min                | 7,500 sq-ft   | 7,500 sq-ft   | 60 ft   | 2 covered spaces per dwelling unit (8)  |
| <b>R1 (including R1V, R1F, R1R, R1H)</b> | <b>One-Family Residential</b><br>RS Uses   |                |                   |   |   |                          | See Table 2 below. Subject to encroachment plane (see p.15) | 20% lot depth; 20 ft max, but not less than prevailing (6b) | 5 ft; or 10% lot width where lot is < 50 ft wide, not less than 3 ft (7); additional 5 ft offset required for side walls >45 ft long & >14 ft high                    |   |

DEPARTMENT OF CITY PLANNING  
GENERALIZED SUMMARY OF ZONING REGULATIONS  
Updated March 2020



Table 1 – General Development Standards

| Zone                        | Use   | Maximum Height |                          | Required Yards   |  |                   | Minimum Area |                   | Min. Lot Width  | Parking Required                           |  |  |             |             |  |   |       |              |             |       |
|-----------------------------|---|----------------|--------------------------|--|--|-------------------|--------------|-------------------|---|--|--|--|-------------|-------------|--|---|-------|--------------|-------------|-------|
|                             |   | Stories        | Feet                     | Front  | Side   | Rear              | Per Lot      | Per Dwelling Unit |   |  |  |  |             |             |  |   |       |              |             |       |
| <b>RU</b>                   | <b>Residential Urban</b>  |                | 30 ft                    | 10 ft  | 3 ft (9)   | 10 ft             | 3,500 sq-ft  | n/a               | 35 ft   | 2 covered parking spaces per dwelling unit |  |  |             |             |  |   |       |              |             |       |
| <b>RZ2.5</b>                |   |                | 45 ft (9)                | 10 ft min  | Zero (3); 3 ft +1 ft for each story over 2nd   | Zero (3) or 15 ft | 2,500 sq-ft  |                   | 30 ft, w/ driveway; 25 ft w/o driveway; 20 ft on flag, curved or cul-de-sac lot |  |  |  |             |             |  |   |       |              |             |       |
| <b>RZ3</b>                  | 3,000 sq-ft   |                |                          |  |  |                   |              |                   |   |  |  |  |             |             |  |   |       |              |             |       |
| <b>RZ4</b>                  | 4,000 sq-ft   |                |                          |  |  |                   |              |                   |   |  |  |  |             |             |  |   |       |              |             |       |
| <b>RW1</b>                  | <b>One-Family Residential Waterways</b><br>One-Family Dwellings, Home Occupations (10)  |                | 30 ft                    |  | 10% lot width; 3 ft min  | 15 ft             | 2,300 sq-ft  |                   | 28 ft   |  |  |  |             |             |  |   |       |              |             |       |
| <b>Multiple Residential</b> |   |                |                          |  |  |                   |              |                   |   |  |  |  |             |             |  |   |       |              |             |       |
| <b>R2</b>                   | <b>Two-Family Dwellings</b><br>R1 Uses, Home Occupations  | Unlimited (9)  | 45 ft or (6a), (7), (9)  | 20% lot depth; 20 ft max, but not less than prevailing | 5 ft; or 10% lot width where lot is < 50 ft wide; 3 ft min (7); additional 5 ft offset required for side walls >45 ft long & >14 ft high | 15 ft             | 5,000 sq-ft  | 2,500 sq-ft       | 50 ft   | 2 spaces, one covered                      |  |  |             |             |  |   |       |              |             |       |
| <b>RD1.5</b>                | <b>Restricted Density Multiple Dwelling</b><br>One-Family Dwellings, Two-Family Dwellings, Apartment Houses, Multiple Dwellings, Home Occupations |                |                          |  |  |                   |              |                   |   |  | 15 ft  | 5 ft; or 10% of lot width where lot is less than <50 ft wide; 3 ft min; +1 ft for each story over 2 <sup>nd</sup> , not to exceed 16 ft (6a) | 15 ft       | 1,500 sq-ft | 1 space per unit < 3 habitable rooms; 1.5 spaces per unit = 3 habitable rooms; 2 spaces per unit > 3 habitable rooms; uncovered (6a) |   |       |              |             |       |
| <b>RD2</b>                  |   |                |                          |  |  |                   |              |                   |   |  |  |  |             | 2,000 sq-ft |  |   |       |              |             |       |
| <b>RD3</b>                  |   |                |                          |  |  |                   |              |                   |   |  |  |  |             | 6,000 sq-ft |  | 3,000 sq-ft   | 60 ft |              |             |       |
| <b>RD4</b>                  |   |                |                          |  |  |                   |              |                   |   |  |  |  |             | 8,000 sq-ft |  | 4,000 sq-ft   |       |              |             |       |
| <b>RD5</b>                  |   |                |                          |  |  |                   |              |                   |   |  |  |  |             | 20 ft       |  | 10 ft (6a)  | 25 ft | 10,000 sq-ft | 5,000 sq-ft | 70 ft |
| <b>RD6</b>                  |   |                |                          |  |  |                   |              |                   |   |  |  |  |             |             |  |   |       | 12,000 sq-ft | 6,000 sq-ft |       |
| <b>RMP</b>                  | <b>Mobile Home Park</b><br>Home Occupations   | 45 or (9)      | 20% lot depth, 25 ft max | 10 ft  | 25% lot depth, 25 ft max   | 20,000 sq-ft      | 20,000 sq-ft | 80 ft             | 2 covered spaces per dwelling unit  |  |  |  |             |             |  |   |       |              |             |       |
| <b>RW2</b>                  | <b>Two-Family Residential Waterways</b><br>One-Family Dwellings, Two-Family Dwellings, Home Occupations   |                |                          |  |  |                   |              |                   |   | 10 ft                                      | 10% lot width; 3 ft min; +1 ft for each story over 2nd | 15 ft  | 2,300 sq-ft | 1,150 sq-ft | 28 ft  | Bicycle Parking pursuant to Sec. 12.21 A.16 of the LAMC |       |              |             |       |

DEPARTMENT OF CITY PLANNING  
GENERALIZED SUMMARY OF ZONING REGULATIONS  
Updated March 2020



**Table 1 – General Development Standards**

| Zone        | Use  | Maximum Height   |      | Required Yards                          |   |   | Minimum Area |                                     | Min. Lot Width | Parking Required |
|-------------|--|------------------|------|---|---|---|--------------|-------------------------------------|----------------|------------------|
|             |  | Stories          | Feet | Front                                   | Side  | Rear  | Per Lot      | Per Dwelling Unit                   |                |                  |
| <b>R3</b>   | <b>Multiple Dwelling</b><br>R2 Uses, Apartment Houses, Multiple Dwellings, Child Care (20 max) |                  |      | 15 ft; 10 ft for key lots               | 5 ft; 10% lot width when lot width is < 50 ft; 3 ft min; +1 ft for each story over 2nd, not to exceed 16 ft | 15 ft   | 5,000 sq-ft  | 800 sq-ft; 500 sq-ft per guest room | 50 ft          | Same as RD Zones |
| <b>RAS3</b> | <b>Residential/Accessory</b><br>R3 uses, Limited ground floor commercial                       |                  |      | 5 ft, or average of adjoining buildings | Zero ft for ground floor commercial, 5 ft for residential   | 15 ft adjacent to RD or more restrictive Zone; otherwise 5 ft |              | 800 sq-ft; 200 sq-ft per guest room |                |                  |
| <b>R4</b>   | <b>Multiple Dwelling</b><br>R3 Uses, Churches, Schools, Childcare, Homeless Shelter            | Unlimited<br>(9) |      | 15 ft; 10 ft for key lots               | 5ft; 10% lot width when lot width is < 50 ft; 3 ft min; +1 ft for each story over 2nd, not to exceed 16 ft  | 15 ft; +1 ft for each story over 3rd; 20 ft max               |              | 400 sq-ft; 200 sq-ft per guest room |                |                  |
| <b>RAS4</b> | <b>Residential/Accessory</b><br>R4 uses, Limited ground floor commercial                       |                  |      | 5 ft, or average of adjoining buildings | Zero ft for ground floor commercial, 5 ft for residential   | 15 ft adjacent to RD or more restrictive Zone; otherwise 5 ft |              |                                     |                |                  |
| <b>R5</b>   | <b>Multiple Dwelling</b><br>R4 Uses, Clubs, Lodges, Hospitals, Sanitariums, Hotels             |                  |      | 15 ft; 10 ft for key lots               | 5ft; 10% lot width when lot width is < 50 ft; 3 ft min; +1 ft for each story over 2nd, not to exceed 16 ft  | 15 ft; +1 ft for each story over 3rd; 20 ft max               |              |                                     |                |                  |

**Loading Space:** Required for the RAS3, R4, RAS4, and R5 Zones in accordance with Section 12.21 C.6 of the LAMC.

**Open Space:** Required for 6 or more residential units in accordance with Section 12.21 G of the LAMC.

**Passageway:** 10 feet required from the street to one entrance of each dwelling unit or guest room in every residential building, except for the RW, RU, and RZ Zones, in accordance with Section 12.21 C.2 of the LAMC.

| <b>Commercial</b> |   |          |              |           |  |  |   |  |   |  |
|-------------------|---|----------|--------------|-----------|--|--|---|--|---|--|
| <b>CR</b>         | <b>Limited Commercial</b><br>Banks, Clubs, Hotels, Churches, Schools, Business and Professional Colleges, Child Care, Parking Areas, Offices, R4 Uses | 6<br>(9) | 75 ft<br>(9) | 10 ft min | For corner lots:<br>10% lot width; 10 ft max; 5 ft min<br><br>For lots adj. to A or R zone or for residential uses:<br>10% lot width; 5 ft max; 3 ft min<br><br>For other lots: not required | 15 ft min; +1 ft for each story over 3rd | Same as R4 for residential uses; otherwise none | 50 ft for residential uses; otherwise none | See separate parking handout<br><br>Bicycle Parking pursuant to Sec. 12.21 A.16 of the LAMC |  |

DEPARTMENT OF CITY PLANNING  
GENERALIZED SUMMARY OF ZONING REGULATIONS  
Updated March 2020



**Table 1 – General Development Standards**

| Zone        | Use  | Maximum Height   |      | Required Yards |  |   | Minimum Area   |                   | Min. Lot Width | Parking Required |
|-------------|--|------------------|------|----------------|--|---|--|-------------------|----------------|------------------|
|             |  | Stories          | Feet | Front          | Side   | Rear  | Per Lot  | Per Dwelling Unit |                |                  |
| <b>C1</b>   | <b>Limited Commercial</b><br>Local Retail Stores < 100,000 sq-ft, Offices or Businesses, Hotels, Hospitals and/or Clinics, Parking Areas, CR Uses except for Churches, Schools, Museums, R3 Uses | Unlimited<br>(9) |      |                | For corner lots, lots adjacent to A or R Zone, or residential uses: 10% lot width; 5 ft max; 3 ft min; +1 ft for each story over 2 <sup>nd</sup> , up to 16 ft<br><br>For other lots: not required; 3 ft min if provided | For residential uses or abutting A or R Zone: 15 ft; +1 ft for each story over 3rd; 20 ft max | Same as R3 Zone for residential uses; otherwise none |                   |                |                  |
| <b>C1.5</b> | <b>Limited Commercial</b><br>C1 Uses – Retail, Theaters, Hotels, Broadcasting Studios, Parking Buildings, Parks and Playgrounds, R4 Uses   |                  |      |                |  |   | Same as R4 Zone for residential uses; otherwise none |                   |                |                  |
| <b>C2</b>   | <b>Commercial</b><br>C1.5 Uses; Retail w/ Limited Manufacturing, Service Stations and Garages, Retail Contr. Business, Churches, Schools, Auto Sales, R4 Uses                                    |                  |      | None           | None for commercial uses; same as R4 Zone for residential uses at lowest residential story   | Same as R4 Zone for residential uses at lowest residential story; otherwise none              |  |                   |                |                  |
| <b>C4</b>   | <b>Commercial</b><br>C2 Uses with Limitation, R4 Uses  |                  |      |                |  |   |  |                   |                |                  |
| <b>C5</b>   | <b>Commercial</b><br>C2 Uses, Limited Floor Area for Manufacturing of CM Zone Type, R4 Uses  |                  |      |                |  |   |  |                   |                |                  |
| <b>CM</b>   | <b>Commercial Manufacturing</b><br>Wholesale, Storage, Clinics, Limited Manufacturing, Limited C2 Uses, R3 Uses  |                  |      |                | None for commercial uses; same as R4 for residential uses  | Same as R3 Zone for residential uses; otherwise none  |  |                   |                |                  |

**Loading Space:** Hospitals, hotels, institutions, and every building where lot abuts an alley. Minimum loading space is 400 sq-ft; additional space for buildings > 50,000 sq-ft of Floor Area. None for apartment buildings < 30 units, in accordance with Section 12.21 C.6 of the LAMC.

**Manufacturing**

|            |  |                  |   |   |   |  |   |
|------------|--|------------------|---|---|---|--|---|
| <b>MR1</b> | <b>Restricted Industrial</b><br>CM Uses, Limited Commercial and Manufacturing, Clinics, Media Products, Limited Machine Shops, Animal Hospitals and Kennels  | Unlimited<br>(9) | 5 ft for lots <100 ft deep; 15 ft for lost >100 ft deep | None for industrial or commercial uses; same as R4 Zone for residential uses<br>(5) | None for industrial or commercial uses; same as R4 Zone for residential uses<br>(5) | None for industrial or commercial uses; same as R4 for residential uses<br>(5) | See separate parking handout<br><br>Bicycle Parking pursuant to Sec. 12.21 A.16 of the LAMC |
| <b>M1</b>  | <b>Limited Industrial</b><br>MR1 Uses, Limited Industrial and Manufacturing Uses, no R Zone Uses, no Hospitals, Schools, Churches, any Enclosed C2 Use, Wireless Telecommunications, Household Storage |                  | None  |   |   |  |   |

DEPARTMENT OF CITY PLANNING  
GENERALIZED SUMMARY OF ZONING REGULATIONS  
Updated March 2020



**Table 1 – General Development Standards**

| Zone   | Use  | Maximum Height   |      | Required Yards   |   |  | Minimum Area   |                   | Min. Lot Width | Parking Required  |
|--|--|------------------|------|--|---|--|--|-------------------|----------------|---|
|  |  | Stories          | Feet | Front  | Side  | Rear   | Per Lot  | Per Dwelling Unit |                |   |
| <b>MR2</b>   | <b>Restricted Light Industrial</b><br>MR1 Uses, Additional Industrial Uses, Mortuaries, Animal Keeping   |                  |      | 5 ft for lots <100 ft deep; 15 ft for lots >100 ft deep                          |   |  | None for industrial or commercial uses; same as R5 for residential uses<br>(5) |                   |                |   |
| <b>M2</b>  | <b>Light Industrial</b><br>M1 and MR2 Uses, Additional Industrial Uses, Storage Yards, Animal Keeping, Enclosed Composting, no R Zone Uses   |                  |      | None   | Same as R5 Zone for residential uses<br>(5)   |  |  |                   |                |   |
| <b>M3</b>  | <b>Heavy Industrial</b><br>M2 Uses, any Industrial I Uses, Nuisance Type Uses 500 ft from any other Zone, no R Zone Uses   |                  |      | None   |   |  | None   |                   |                |   |
| <b>Loading Space:</b> Institutions, and every building where lot abuts an alley. Minimum loading space is 400 sq-ft; additional space for buildings > 50,000 sq-ft of floor area. None for apartment buildings < 30 units, in accordance with Section 12.21 C.6 of the LAMC. |  |                  |      |  |   |  |  |                   |                |   |
| <b>Parking</b>   |  |                  |      |  |   |  |  |                   |                |   |
| <b>P</b>   | <b>Automobile Parking – Surface and Underground</b><br>Surface Parking; Parking Buildings if located below grade; Land in a P Zone may also be classified in A or R Zone   | Unlimited<br>(9) |      | 10 ft in combination with an A or R Zone; otherwise none                         | None  |  | None, unless also in an A or R Zone  |                   |                | See separate parking handout<br><br>Bicycle Parking pursuant to Sec. 12.21 A.16 of the LAMC |
| <b>PB</b>  | <b>Parking Building</b><br>P Zone uses, Parking Buildings at or above grade; Automobile Parking within a Building  |                  |      | 0 ft, 5, ft, or 10 ft, depending on zoning frontage and zoning across the street | 5 ft + 1 ft each story above 2nd if abutting or across street and frontage in A or R Zone | 5 ft + 1 ft each story above 2nd if abutting A or R Zone | None   |                   |                |   |
| <b>Open Space/Public Facilities/Submerged Lands</b>  |  |                  |      |  |   |  |  |                   |                |   |
| <b>OS</b>  | <b>Open Space</b><br>Parks and Recreation Facilities, Nature Reserves, Closed Sanitary Landfill sites, Public Water Supply Reservoirs, Water Conservation Areas  | None             |      | None   |   |  | None   |                   |                | See separate parking handout<br><br>Bicycle Parking pursuant to Sec. 12.21 A.16 of the LAMC |
| <b>PF</b>  | <b>Public Facilities</b><br>Agricultural Uses, Parking Under Freeways, Fire and Police Stations, Government Buildings, Public Libraries, Post Offices, Public Health Facilities, Public Elementary and Secondary Schools, Qualified Permanent Supportive Housing Projects (12) |                  |      |  |   |  |  |                   |                |   |

**DEPARTMENT OF CITY PLANNING**  
**GENERALIZED SUMMARY OF ZONING REGULATIONS**  
*Updated March 2020*



**Table 1 – General Development Standards**

| Zone | Use   | Maximum Height |      | Required Yards |      |      | Minimum Area |                   | Min. Lot Width | Parking Required |
|------|---|----------------|------|----------------|------|------|--------------|-------------------|----------------|------------------|
|      |   | Stories        | Feet | Front          | Side | Rear | Per Lot      | Per Dwelling Unit |                |                  |
| SL   | Submerged Lands<br>Navigation, Shipping, Fishing,<br>Recreation |                |      |                |      |      |              |                   |                |                  |

- (1) "H" Hillside or Mountainous Areas may alter these requirements in the RA-H or RE-H Zones. Subdivision may be approved with smaller lots, provided larger lots are also included. Section 17.05 H.1 of the LAMC.
- (2) Section 12.08.3 B.1 of the LAMC.
- (3) Section 12.08.3 C.2 and 3 of the LAMC.
- (4) Section 12.09.5 C of the Zoning Code. For 2 or more lots, the interior side yards may be eliminated, but 4 ft is required on each side of the grouped lots.
- (5) Section 12.17.5 B.9(a) of the LAMC. Dwelling considered as accessory to industrial use only (watchman or caretaker including family).
- (6)
  - a. Height, yard and parking requirement for single-family dwellings in a designated Hillside Area may be governed by Section 12.21 A.17 of the LAMC.
  - b. Height, yard and parking requirements for single-family dwellings in a designated Hillside Area may be governed by Section 12.21 C.10 of the LAMC.
- (7) One foot shall be added to the width of each required side yard for each increment of ten feet, or fraction thereof, above the first 18 feet of height of the main building. On lots within the Coastal Zone, not located within a Hillside Area as defined in Section 12.03 of the LAMC, one foot shall be added to the width of each required side yard for each additional story above the second story; except on RA lots where a side yard of less than 10 feet in width is permitted, one foot shall be added to the width of each required side yard when a building is three or more stories in height.
- (8) In accordance with Section 12.21 C.10(g) of the LAMC, on a Substandard Hillside Limited Street, when buildings exceed 2,400 sq-ft of Residential Floor Area, one additional parking space will be provided for each additional increment of 1,000 sq-ft, or fraction thereof, for a maximum of 5 total on-site spaces.
- (9) Height District (Section 12.21.1 of the LAMC), see Table 2 – Height Districts.
- (10) The side yard on one side of the lot may be reduced to zero provided that the remaining side yard is increased to 6 ft, in accordance with Section 12.08.1 C.2 of the LAMC.
- (11) Specific Requirements for open space, rear yards, and provisions into front yards are in Section 12.08.5 C of the LAMC.
- (12) Section 12.04.09 B.11 of the LAMC. Qualified Permanent Supportive Housing Projects are permitted in the PF Zone utilizing the uses and standards permitted by the least restrictive adjoining zone.

**Table 2 – Height Districts (Height, Stories, FAR & RFAR)**

| Zone                                    | 1†   | 1L† | 1VL†   | 1XL†  | 1SS   | 2  | 3   | 4   |
|---|--|-----|--|---|---|--|---|---|
| <b>A1‡, A2‡, RZ, RMP, RW2</b>           | Height: 45 ft<br>Stories: n/a<br>FAR: 3:1                      |     | Height: 45 ft<br>Stories: 3†<br>FAR: 3:1                       | Height: 30 ft<br>Stories: 2†<br>FAR: 3:1  | n/a   | Height: n/a<br>Stories: n/a<br>FAR: 6:1                        | Height: n/a<br>Stories: n/a<br>FAR: 10:1  | Height: n/a<br>Stories: n/a<br>FAR: 13:1  |
| <b>RD‡, R3</b>                          | Height: 45 ft<br>Stories: n/a<br>FAR: 3:1                      |     | Height: 45 ft<br>Stories: 3†<br>FAR: 3:1                       | Height: 30 ft<br>Stories: 2†<br>FAR: 3:1  | n/a   | Height: 75 ft<br>Stories: 6†<br>FAR: 6:1                       | Height: 75 ft<br>Stories: 6†<br>FAR: 10:1 | Height: 75 ft<br>Stories: 6†<br>FAR: 13:1 |
| <b>RAS3</b>                             | Height: 45 ft<br>Stories: n/a<br>FAR: 3:1                      |     | Height: 50 ft<br>Stories: n/a<br>FAR: 3:1                      | Height: 30 ft<br>Stories: n/a<br>FAR: 3:1   | n/a   | Height: 75 ft<br>Stories: 6†<br>FAR: 6:1                       | Height: 75 ft<br>Stories: 6†<br>FAR: 10:1 | Height: 75 ft<br>Stories: 6†<br>FAR: 13:1 |
| <b>RA*§, RE40§, RE20§, RE15§, RE11§</b> | Height<br>Roof ≥25%, 36 ft<br>Roof <25%, 30 ft<br>Stories: n/a |     | Height<br>Roof ≥25%, 30 ft<br>Roof <25%, 30 ft<br>Stories: n/a | Height<br>Roof ≥25%, 18 ft (22 ft in Hillside Area)<br>Roof <25%, 18 ft<br>Stories: n/a | Height<br>Roof ≥25%, 18 ft (22 ft in Hillside Area)<br>Roof <25%, 18 ft<br>Stories: n/a | Height<br>Roof ≥25%, 36 ft<br>Roof <25%, 30 ft<br>Stories: n/a |   |   |

**DEPARTMENT OF CITY PLANNING**  
**GENERALIZED SUMMARY OF ZONING REGULATIONS**  
*Updated March 2020*



**Table 2 – Height Districts (Height, Stories, FAR & RFAR)**

| Zone   | 1†   | 1L†   | 1VL†  | 1XL†   | 1SS   | 2  | 3  | 4   |   |
|--|--|---|---|--|---|--|--|---|---|
|  | <b>RFAR:</b> See C.5 of each Zone in the LAMC; for Hillside Area, see Section 12.21 C.10 of the LAMC<br><b>FAR (Coastal Zone, non-Hillside only)***:</b> See Section 12.21.1 A of the LAMC     |   |   |  |   | <b>RFAR:</b> N/A.<br><b>FAR:</b> 6:1                           | <b>RFAR:</b> N/A.<br><b>FAR:</b> 10:1  | <b>RFAR:</b> N/A.<br><b>FAR:</b> 13:1   |   |
| <b>RE9*§,</b><br><b>RS§,</b><br><b>R1**§</b> | <b>Height</b><br>Roof ≥25%: 33 ft<br>Roof <25%: 28 ft<br><b>Stories:</b> n/a<br>R1 subject to Encroachment Plane; see p.15.  |   | <b>Height</b><br>Roof ≥25%: 30 ft<br>Roof <25%: 28 ft<br><b>Stories:</b> n/a<br>R1 subject to Encroachment Plane; see p.15. | <b>Height</b><br>Roof ≥25%, 18 ft (22 ft in Hillside Area)<br>Roof <25%, 18 ft<br><b>Stories:</b> n/a<br>R1 subject to Encroachment Plane; see p.15. | <b>Height</b><br>Roof ≥25%: 33 ft<br>Roof <25%: 28 ft<br><b>Stories:</b> n/a<br>R1 subject to Encroachment Plane; see p.15. |  |  |   |   |
|  | <b>RFAR:</b> See C.5 of each Zone in the LAMC; for Hillside Area, see Section 12.21 C.10(b) of the LAMC.<br><b>FAR (Coastal Zone, non-Hillside only)***:</b> See Section 12.21.1 A of the LAMC |   |   |  |   | <b>RFAR:</b> N/A<br><b>FAR:</b> 6:1                            | <b>RFAR:</b> N/A<br><b>FAR:</b> 10:1   | <b>RFAR:</b> N/A<br><b>FAR:</b> 13:1  |   |
| <b>R2</b>                                    | <b>Height:</b> 33 ft<br><b>Stories:</b> n/a<br><b>FAR:</b> 3:1   | <b>Height:</b> 33 ft<br><b>Stories:</b> 3†<br><b>FAR:</b> 3:1   | <b>Height:</b> 30 ft<br><b>Stories:</b> 2†<br><b>FAR:</b> 3:1   | n/a  |   | <b>Height:</b> 33 ft<br><b>Stories:</b> n/a<br><b>FAR:</b> 6:1 | <b>Height:</b> 33 ft<br><b>Stories:</b> n/a<br><b>FAR:</b> 10:1  | <b>Height:</b> 33 ft<br><b>Stories:</b> n/a<br><b>FAR:</b> 13:1   |   |
| <b>R4, R5</b>                                | <b>Height:</b> n/a<br><b>Stories:</b> n/a<br><b>FAR:</b> 3:1   | <b>Height:</b> 75 ft<br><b>Stories:</b> 6†<br><b>FAR:</b> 3:1   | <b>Height:</b> 45 ft<br><b>Stories:</b> 3†<br><b>FAR:</b> 3:1   | <b>Height:</b> 30 ft<br><b>Stories:</b> 2†<br><b>FAR:</b> 3:1  | n/a   |  | <b>Height:</b> n/a<br><b>Stories:</b> n/a<br><b>FAR:</b> 6:1   | <b>Height:</b> n/a<br><b>Stories:</b> n/a<br><b>FAR:</b> 10:1   | <b>Height:</b> n/a<br><b>Stories:</b> n/a<br><b>FAR:</b> 13:1   |
| <b>RAS4</b>                                  | <b>Height:</b> n/a<br><b>Stories:</b> n/a<br><b>FAR:</b> 3:1   | <b>Height:</b> 75 ft<br><b>Stories:</b> 6†<br><b>FAR:</b> 3:1   | <b>Height:</b> 50 ft<br><b>Stories:</b> 3†<br><b>FAR:</b> 3:1   | <b>Height:</b> 30 ft<br><b>Stories:</b> 2†<br><b>FAR:</b> 3:1  | n/a   |  | <b>Height:</b> n/a<br><b>Stories:</b> n/a<br><b>FAR:</b> 6:1   | <b>Height:</b> n/a<br><b>Stories:</b> n/a<br><b>FAR:</b> 10:1   | <b>Height:</b> n/a<br><b>Stories:</b> n/a<br><b>FAR:</b> 13:1   |
| <b>C, M</b>                                  | <b>Height:</b> 75 ft for CR, otherwise n/a<br><b>Stories:</b> 6 for CR, otherwise n/a<br><b>FAR:</b> 1.5:1   | <b>Height:</b> 75 ft<br><b>Stories:</b> 6†<br><b>FAR:</b> 1.5:1 | <b>Height:</b> 45 ft<br><b>Stories:</b> 3†<br><b>FAR:</b> 1.5:1   | <b>Height:</b> 30 ft<br><b>Stories:</b> 2†<br><b>FAR:</b> 1.5:1  | n/a   |  | <b>Height:</b> 75 ft for CR, otherwise n/a<br><b>Stories:</b> 6 for CR, otherwise n/a<br><b>FAR:</b> 6:1 | <b>Height:</b> 75 ft for CR, otherwise n/a<br><b>Stories:</b> 6 for CR, otherwise n/a<br><b>FAR:</b> 10:1 | <b>Height:</b> 75 ft for CR, otherwise n/a<br><b>Stories:</b> 6 for CR, otherwise n/a<br><b>FAR:</b> 13:1 |
| <b>PB</b>                                    | <b>Height:</b> n/a<br><b>Stories:</b> 2<br><b>FAR:</b> n/a   | <b>Height:</b> 75 ft<br><b>Stories:</b> 2<br><b>FAR:</b> n/a    | <b>Height:</b> 45 ft<br><b>Stories:</b> 2<br><b>FAR:</b> n/a  | <b>Height:</b> 30 ft<br><b>Stories:</b> 2<br><b>FAR:</b> n/a   | n/a   |  | <b>Height:</b> n/a<br><b>Stories:</b> 6<br><b>FAR:</b> n/a   | <b>Height:</b> n/a<br><b>Stories:</b> 10<br><b>FAR:</b> n/a   | <b>Height:</b> n/a<br><b>Stories:</b> 13<br><b>FAR:</b> n/a   |
| <b>PF</b>                                    | <b>Height:</b> n/a<br><b>Stories:</b> n/a<br><b>FAR:</b> 3:1   | <b>Height:</b> 75 ft<br><b>Stories:</b> 6†<br><b>FAR:</b> 3:1   | <b>Height:</b> 45 ft<br><b>Stories:</b> 3†<br><b>FAR:</b> 3:1   | <b>Height:</b> 30 ft<br><b>Stories:</b> 2†<br><b>FAR:</b> 3:1  | n/a   |  | <b>Height:</b> n/a<br><b>Stories:</b> n/a<br><b>FAR:</b> 6:1   | <b>Height:</b> n/a<br><b>Stories:</b> n/a<br><b>FAR:</b> 10:1   | <b>Height:</b> n/a<br><b>Stories:</b> n/a<br><b>FAR:</b> 13:1   |

DEPARTMENT OF CITY PLANNING  
 GENERALIZED SUMMARY OF ZONING REGULATIONS  
 Updated March 2020



**Table 2 – Height Districts (Height, Stories, FAR & RFAR)**

| Zone | 1† | 1L‡ | 1VL‡ | 1XL‡ | 1SS | 2 | 3 | 4 |
|------|----|-----|------|------|-----|---|---|---|
|------|----|-----|------|------|-----|---|---|---|

FAR – Floor Area Ratio – defined in Section 12.03 of the LAMC.

RFAR – Residential Floor Area Ratio – defined in Section 12.03 of the LAMC. Used only for non-Coastal Zone properties in Height Districts 1, 1L, 1VL, 1XL, and 1SS.

\* Prevailing Height in accordance with the 3rd unnumbered paragraphs of Section 12.21.1 of the LAMC may apply.

\*\* Properties located in one of the R1 Variation Zones (R1V, R1F, R1R, R1H) are not part of any Height District. See tables on pp.11-14 for height regulations in R1 Variation Zones. These regulations are also in Section 12.08 C.5 (b)-(d) of the LAMC.

\*\*\*Coastal Zone properties outside of the Hillside Area are not subject to Residential Floor Area limits, but are subject to Floor Area limits.

† Buildings used entirely for residential (and ground floor commercial in the RAS Zones) are only limited as to feet, not stories.

‡ Floor Area in Height District 1 in other than C and M Zones is limited to 3:1 FAR.

⌘ Height limited to 36 ft or 45 ft in Hillside Areas in accordance with Section 12.21 A.17 of the LAMC.

§ Height limited to 45 feet on lots in the Coastal Zone not located within the Hillside Area, as defined in Section 12.03 of the LAMC.

**Transitional Height:** Portions of buildings in C or M Zones within certain distances of RW1 or more restrictive Zones shall not exceed the following height limits, in accordance with Section 12.21.1 A.10 of the LAMC.

| Distance (ft) | Height (ft) |
|---------------|-------------|
| 0 – 49        | 25          |
| 50 – 99       | 33          |
| 100 – 199     | 61          |



DEPARTMENT OF CITY PLANNING  
 GENERALIZED SUMMARY OF ZONING REGULATIONS  
 Updated March 2020



ANATOMY OF ZONING IN LOS ANGELES

[Q]C2-1-CDO

**SPECIAL ZONING CLASSIFICATIONS**

Site-specific or project-specific provisions that are established by ordinance as part of the Zone for a lot.

**ZONE CLASSIFICATIONS**

The zone classification dictates basic requirements and restrictions such as permitted and conditionally permitted uses, minimum lot area, yard and parking requirements.

**HEIGHT DISTRICT**

The height district designation determines the maximum Floor Area Ratio, Residential Floor Area Ratio, and sometimes number of stories and/or feet. Does not apply to R1 Variation Zones.

**SUPPLEMENTAL USE DISTRICT**

Supplemental use districts contain *additional* regulations beyond those required by the base zone regulations, usually to protect or create certain neighborhood characteristics.

**Special Zoning Classifications** (Section 12.32 of the LAMC. T and Q Classifications appear before the zone classification, while D limitations appear after the height district designation.)

|                    |                               |  |
|--------------------|-------------------------------|--|
| <b>(T), [T], T</b> | Tentative Zone Classification | Tentative zone classification, pending certain required dedications, payments or improvements – see Council File |
| <b>(Q), [Q], Q</b> | Qualified Classification      | Restricts uses allowed on property   |
| <b>D</b>           | Development Limitation        | Restricts heights, floor area ratio, lot coverage, building setbacks   |

**Supplemental Use Districts**

Regulate uses which cannot adequately be provided for in the Zoning Code (Section 13.00 of the LAMC)

|            |  |             |  |
|------------|--|-------------|--|
| <b>O</b>   | Oil Drilling District                    | <b>MU</b>   | Mixed Use District                             |
| <b>S</b>   | Animal Slaughtering                      | <b>FH</b>   | Fence Height District                          |
| <b>G</b>   | Surface Mining District                  | <b>SN</b>   | Sign District                                  |
| <b>RPD</b> | Residential Planned Development District | <b>RFA</b>  | Residential Floor Area District                |
| <b>K</b>   | Equinekeeping District                   | <b>NSO</b>  | Neighborhood Stabilization Overlay District    |
| <b>CA</b>  | Commercial and Artcraft District         | <b>CPIO</b> | Community Plan Implementation Overlay District |
| <b>POD</b> | Pedestrian Oriented District             | <b>HS</b>   | Hillside Standards Overlay District            |
| <b>CDO</b> | Community Design Overlay District        | <b>MPR</b>  | Modified Parking Requirement District          |

**Other Zoning Designations**

|             |                                    |              |   |
|-------------|------------------------------------|--------------|---|
| <b>ADP</b>  | Alameda District Specific Plan     | <b>LASED</b> | LA Sports & Entertainment Specific Plan |
| <b>CCS</b>  | Century City South Studio Zone     | <b>OX</b>    | Oxford Triangle Specific Plan           |
| <b>CSA</b>  | Centers Study Area                 | <b>PKM</b>   | Park Mile Specific Plan                 |
| <b>CW</b>   | Central City West Specific Plan    | <b>PV</b>    | Playa Vista Specific Plan               |
| <b>GM</b>   | Glencoe/Maxella Specific Plan      | <b>WC</b>    | Warner Center Specific Plan             |
| <b>HPOZ</b> | Historic Preservation Overlay Zone |              |   |

DEPARTMENT OF CITY PLANNING  
GENERALIZED SUMMARY OF ZONING REGULATIONS  
*Updated March 2020*



**GENERAL NOTE:**

This summary is only a guide. Definitive information should be obtained from Chapter 1 of the Los Angeles Municipal Code (LAMC) itself and from consultation with the Department of Building and Safety.

**UPDATES:**

*April 2013 Update:* Updated to reflect changes made to the Single-Family Zones under the Baseline Mansionization Ordinance (Ord. No. 179,883) and Baseline Hillside Ordinance (Ord. No. 181,624), bicycle parking requirements under Bicycle Parking Ordinance (Ord. No. 182,386), the list of Supplemental Use Districts, and add the "ANATOMY OF ZONING IN LOS ANGELES" diagram.

*May 2019 Update:* Updated to reflect further changes to the Single-Family Zone Regulations and addition of R1 Variation Zones (Ord. No. 184,802), and the Permanent Supportive Housing Ordinance (Ord. No. 185,492).

*June 2019 Correction:* Corrected height restrictions for C and M properties in Height Districts 1VL and 1XL.

*March 2020 Correction:* Corrected FAR/RFAR restrictions for R1, RA, RE and RS properties in Height Districts 2, 3 and 4.



## R1 Variation Zones – Bulk & Massing Regulations

The following pages contain summaries of the bulk and massing regulations for the R1 Variation Zones, which are divided into “R1V” Variable-Mass, “R1F” Front-Mass, “R1R” Rear-Mass, and R1H” Hillside. All of the R1 Variation Zones are subject to encroachment plane limits, as well as the side yard plane break/offset requirement for all R1 properties. The encroachment plane and plane break/offset requirements are illustrated on Pages 15-16.

### “R1V” Variable-Mass Zones (R1V1, R1V2, R1V3, R1V4)

| Table 12.08 C.5(b)                                     |                                  |      |      |      |                  |  |
|--|----------------------------------|------|------|------|------------------|--|
| R1 VARIABLE-MASS VARIATION ZONES DEVELOPMENT STANDARDS |                                  |      |      |      |                  |  |
|  |                                  |      |      |      |                  |  |
| Lot Size and Residential Floor Area Ratio              | R1V1                             | R1V2 | R1V3 | R1V4 | Max Lot Coverage |  |
| Up to 6,000 SF   | .65                              | .55  | .45  | .40  | 50%              |  |
| 6,001 to 7,000 SF                                      | .63                              | .53  | .43  | .38  | 48%              |  |
| 7,001 to 8,000 SF                                      | .61                              | .51  | .41  | .36  | 46%              |  |
| 8,001 to 9,000 SF                                      | .59                              | .49  | .39  | .34  | 44%              |  |
| 9,001 to 10,000 SF                                     | .57                              | .47  | .37  | .32  | 42%              |  |
| Over 10,000 SF   | .55                              | .45  | .35  | .30  | 40%              |  |
| Variable Mass  |                                  |      |      |      |                  |  |
| (A)  | Height of Building (max)         | 30'  | 30'  | 28'  | 20'              |  |
| (B)  | Encroachment Plane Origin Height | 22'  | 22'  | 20'  | 14'              |  |
|  | Angle of Encroachment Plane      | 45°  | 45°  | 45°  | 45°              |  |

DEPARTMENT OF CITY PLANNING  
GENERALIZED SUMMARY OF ZONING REGULATIONS  
Updated March 2020



**“R1F” Front-Mass Zones (R1F1, R1F2, R1F3, R1F4)**

| Table 12.08 C.5(c)                                  |   |      |      |      |      |                  |
|---|---|------|------|------|------|------------------|
| R1 FRONT-MASS VARIATION ZONES DEVELOPMENT STANDARDS |   |      |      |      |      |                  |
|   |   |      |      |      |      |                  |
| Lot Size and Residential Floor Area Ratio           |   | R1F1 | R1F2 | R1F3 | R1F4 | Max Lot Coverage |
|   | Up to 6,000 SF                                      | .65  | .55  | .45  | .40  | 50%              |
|   | 6,001 to 7,000 SF                                   | .63  | .53  | .43  | .38  | 48%              |
|   | 7,001 to 8,000 SF                                   | .61  | .51  | .41  | .36  | 46%              |
|   | 8,001 to 9,000 SF                                   | .59  | .49  | .39  | .34  | 44%              |
|   | 9,001 to 10,000 SF                                  | .57  | .47  | .37  | .32  | 42%              |
|   | Over 10,000 SF                                      | .55  | .45  | .35  | .30  | 40%              |
| Front Mass  |   |      |      |      |      |                  |
| (A)   | Front envelope depth, from front yard setback (min) | -    | -    | -    | -    |                  |
| (B)   | Height of Mass (max)                                | 30'  | 30'  | 28'  | 26'  |                  |
| (C)   | Encroachment Plane Origin Height                    | 22'  | 22'  | 20'  | 18'  |                  |
|   | Angle of Encroachment Plane                         | 45°  | 45°  | 45°  | 45°  |                  |
| Rear Mass   |   |      |      |      |      |                  |
| (D)   | Rear envelope depth, from rear yard setback (min)   | 25'  | 25'  | 25'  | 25'  |                  |
| (E)   | Height of Mass (max)                                | 24'  | 24'  | 20'  | 18'  |                  |
| (F)   | Encroachment Plane Origin Height                    | 16'  | 16'  | 14'  | 14'  |                  |
|   | Angle of Encroachment Plane                         | 45°  | 45°  | 45°  | 45°  |                  |



**“R1R” Rear-Mass Zones (R1R1, R1R2, R1R3, R1R4)**

Table 12.08 C.5(d)

**R1 REAR-MASS VARIATION ZONES DEVELOPMENT STANDARDS**

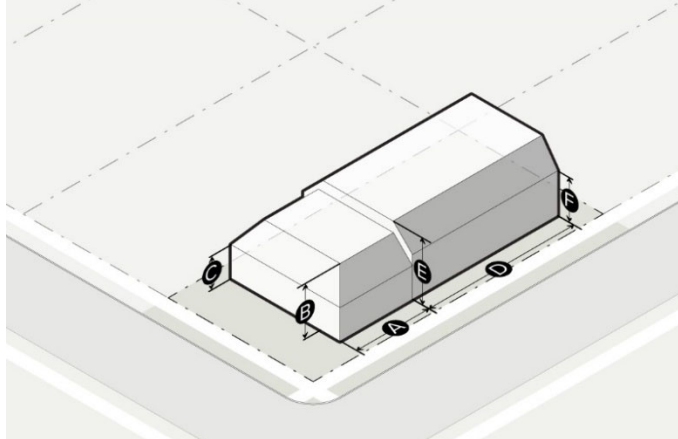

| Lot Size and Residential Floor Area Ratio |   | R1R1 | R1R2 | R1R3 | R1R4 | Max Lot Coverage |
|---|---|------|------|------|------|------------------|
|   | Up to 6,000 SF                                      | .65  | .55  | .45  | .40  | 50%              |
|   | 6,001 to 7,000 SF                                   | .63  | .53  | .43  | .38  | 48%              |
|   | 7,001 to 8,000 SF                                   | .61  | .51  | .41  | .36  | 46%              |
|   | 8,001 to 9,000 SF                                   | .59  | .49  | .39  | .34  | 44%              |
|   | 9,001 to 10,000 SF                                  | .57  | .47  | .37  | .32  | 42%              |
|   | Over 10,000 SF                                      | .55  | .45  | .35  | .30  | 40%              |
| Front Mass                                |   |      |      |      |      |                  |
| (A)                                       | Front envelope depth, from front yard setback (min) | 30'  | 30'  | 30'  | 30'  |                  |
| (B)                                       | Height of Mass (max)                                | 24'  | 24'  | 20'  | 18'  |                  |
| (C)                                       | Encroachment Plane Origin Height                    | 16'  | 16'  | 12'  | 12'  |                  |
|   | Angle of Encroachment Plane                         | 45°  | 45°  | 45°  | 45°  |                  |
| Rear Mass                                 |   |      |      |      |      |                  |
| (D)                                       | Rear envelope depth, from rear yard setback (min)   | -    | -    | -    | -    |                  |
| (E)                                       | Height of Mass (max)                                | 30'  | 30'  | 28'  | 26'  |                  |
| (F)                                       | Encroachment Plane Origin Height                    | 22'  | 22'  | 20'  | 18'  |                  |
|   | Angle of Encroachment Plane                         | 45°  | 45°  | 45°  | 45°  |                  |



**“R1H” Hillside Zones (R1H1, R1H2, R1H3, R1H4)**

The maximum Residential Floor Area contained in all Buildings and Accessory Buildings on a property in an R1H Zone shall not exceed the sum of the square footage of each Slope Band multiplied by the corresponding Residential Floor Area Ratio (RFAR) for the zone of the Lot. Otherwise, a property in an R1H Zone shall comply with all of the R1 Hillside Area Development Standards pursuant to Section 12.21 C.10 of the LAMC.

| Table 12.21 C.10-2b<br>Single-Family Zone Hillside Area Residential Floor Area Ratios (RFAR) |      |      |      |      |
|--|------|------|------|------|
| Slope Bands (%)  | R1H1 | R1H2 | R1H3 | R1H4 |
| <b>0 – 14.99</b>   | 0.65 | 0.55 | 0.45 | 0.40 |
| <b>15 – 29.99</b>  | 0.60 | 0.50 | 0.45 | 0.35 |
| <b>30 – 44.99</b>  | 0.55 | 0.45 | 0.40 | 0.30 |
| <b>45 – 59.99</b>  | 0.50 | 0.40 | 0.35 | 0.25 |
| <b>60 – 99.99</b>  | 0.45 | 0.35 | 0.30 | 0.20 |
| <b>100 +</b>   | 0.00 | 0.00 | 0.00 | 0.00 |



## R1 Encroachment Plane

The Encroachment Plane in the standard R1 Zone and R1 Variation Zones is an angled plane originating at a specified height above the minimum front and/or side yard setback and angling toward the interior of the lot. The mass of the building may not extend above the plane, except for specified roof structures and equipment, per LAMC Section 12.21.1. The 20-foot origin height shown here applies in the standard R1 Zone and in some R1 Variation Zones, while other R1 Variation Zones may specify a different origin height. See Subdivision C.5 of LAMC Section 12.08 for the precise dimensions that apply in each R1 Variation Zone.

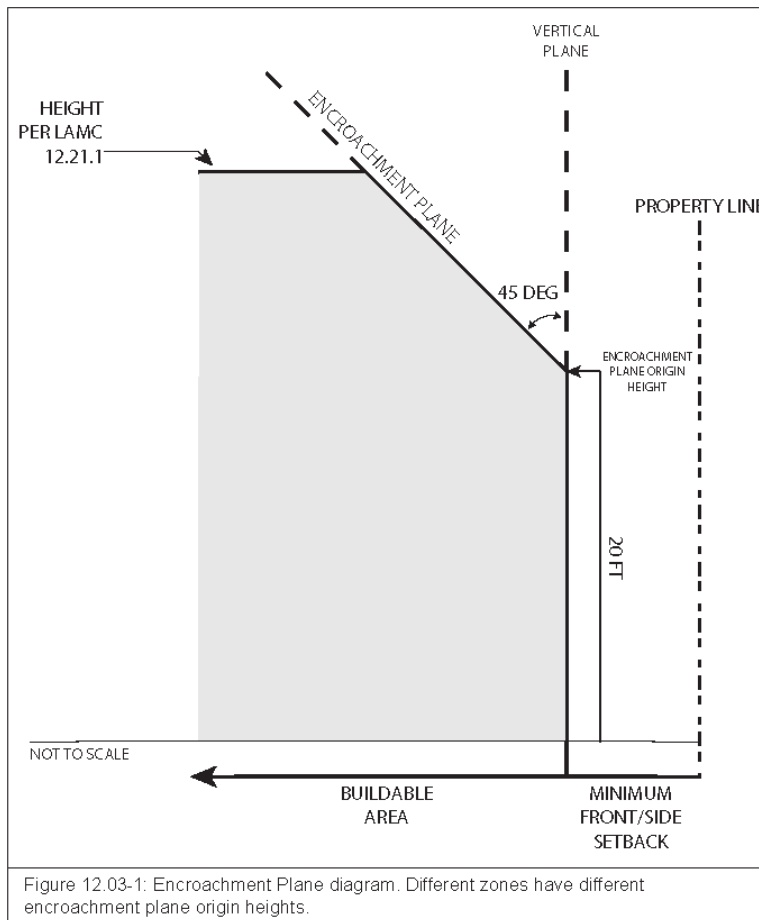



## R1 Side Wall Offset/Plane Break

In the R1 Zone, R2 Zone, and all R1 Variation Zones, all portions of a building that have a side wall more than 14 feet high and a continuous length greater than 45 feet must provide an offset or plane break at least 5 feet in depth beyond the minimum side yard. The offset or plane break must be at least 10 feet in length.

